



A BULLETIN
FROM
TIFAC

INTELLECTUAL PROPERTY RIGHTS (IPR)

VOL 7 NO. 11 NOVEMBER-DECEMBER, 2001

US Supreme Court Affirms Patent for Sexually Reproduced Plant

The US Supreme Court is credited with many landmark decisions which opened doors for patenting of those inventions which were earlier not considered patentable. First it was the genetically modified microorganisms and then computer software, which were included in the list of patentable subject matter, based on two decisions by the Supreme Court. On December 10, 2001 the US Supreme Court affirmed the validity of a utility patent awarded by the US Patent and Trademark Office (USPTO) for sexually reproduced plants in an infringement lawsuit between Pioneer Hi-Bred International Inc. and J.E.M. AG Supply Inc. It may be noted that the USPTO otherwise awards plant patents which do not cover sexually reproduced plants. That is why the present development assumes a great deal of importance.

Background: Pioneer Hi-Bred International Inc, the world's

largest producer of seed corn filed an infringement suit against J.E.M. AG Supply Inc. for infringing its patents for sexually produced corn hybrids.

Pioneer Hi-Bred International, Inc. (Pioneer), holds 17 utility patents issued under 35 U.S.C. 101 that covers the manufacture, use, sale, and offer for sale of its inbred and hybrid corn seed products. Pioneer generally sells its patented hybrid seeds under a limited label license that allows only the production of grain and / or forage, and prohibits using such seeds for propagation or seed multiplication or for the production or development of a hybrid or different seed variety. One could obviously conclude that no further developmental work on the seeds supplied by Pioneer is allowed by Pioneer. Defendant J.E.M. Ag Supply Inc., doing business as Farm Advantage Inc., bought patented seeds from Pioneer in bags bearing the license agreement and then resold the bags. Pioneer filed this patent infringement suit against Farm

Advantage and distributors and customers of Farm Advantage (collectively Farm Advantage or defendants).

Farm Advantage filed a patent invalidity counter claim, arguing that sexually reproduced plants are not patentable subject matter within 35 U.S.C. 101. Further, Farm Advantage maintained that the Plant Patent Act (PPA) provisions allow only patenting of asexually produced plants. It was further argued that sexually reproduced plants were protected under PVPA and hence Utility Patent Act and PVPA were in irreconcilable conflict as the two regimes provided different protection schemes for the same subject matter. Utility patents are granted by the USPTO for all types of inventions.

Utility patents and PVPA have different conditions for protection, different application requirements and so also a different breadth of protection. Utility patent protection is granted to inventions that are new, useful and non-obvious whereas PVPA protection is

Contd on...2

Do not publish your invention before filing a patent application

available to sexually reproduced or tuber-propagated plant varieties that are new, distinct, uniform and stable. So sexually reproduced plant variety may not qualify for utility patent but still qualify for plant variety protection. Secondly, the application requirements under PVPA only includes a description of the plant along with a deposit of seed in a public depository as against description of the invention, description of best mode and one or more claims, in case of utility models. Utility patent is more difficult to obtain but its scope of protection is not relegated to a specific plant variety as in case of a PVPA, rather it extends to a class or species of plants. Also under PVPA there are certain exemptions like farmers saving seed for their own use shall not constitute infringement under PVPA but the same shall constitute infringement under the utility patent regime.

First the District Court held that 35 U.S.C. 101 clearly covers plant life as it defines patentable subject matter "any new and useful process, machine, manufacture, or composition of matter or any new and useful improvement thereof". It noted that, while enacting PPA and PVPA the Congress neither expressly nor implicitly removed plants from 35 U.S.C. 101's

subject matter. Further, Congress did not repeal 35 U.S.C. 101 while passing the more specific PVPA because it did not find any conflict between two statutes. The Court held that newly developed plant breeds fall within the subject matter of 35 U.S.C. 101, and neither the PPA nor the PVPA limits the scope of 101's coverage. Hence, the plea of Farm Advantage was rejected and it was held to infringe Pioneer's patents. The decision of the District Court was affirmed by the US Court of Appeals for the Federal Circuit. The case was then taken to the US Supreme Court in October 2001 which affirmed the earlier decisions of the District Court and the Federal Circuit. In a 9 member bench headed by the Justice J. Thomas, 6 members supported the decision, 2 did not agree and 1 member did not take part. While arriving at the decision, following points were considered:-

1) Whether requirements for securing protection and rights conferred under PVPA are different from utility patents? Both parties confirmed that they were different.

2) Whether a farmer's unauthorized use of seeds derived from plants grown with patented seeds would infringe utility patent even though PVPA exempts such case? Counsels

for both parties confirmed this saying that greater disclosure and higher standards for obtaining a utility patent warrant greater scope of protection.

3) Whether US Congress would give a clear statement that the PVPA excluded sexually reproduced plants from utility patent protection? In the absence of any explicit statements of such kind, J.E.M. argued that the enactment of PVPA and differences between statutes implied Congress' intentions of excluding sexually reproduced plants from the scope of patentable subject matter under 35 U.S.C. 101. But implications and unenacted beliefs cannot have the force of the law.

4) What effect the ruling would have on earlier plant patents granted if the ruling went in favour of J.E.M.? Till September 30, 2001 USPTO had already issued 1,800 utility patents for plants including seeds. An adverse ruling in this case would render all such earlier patents invalid.

The earlier case of Diamond vs Chakrabarty went in favour of utility patents being granted for sexually reproduced plants. It may be recalled that the Court in the Chakrabarty case had ruled that anything under the sun made by man was a patentable subject matter.

Contd on...3

Visit us at www.indianpatents.org.in

As compared to the earlier decisions of the Supreme Court, this case has quite a different history and background. *In the earlier instances, the US Supreme Court had gone against the stand taken by the USPTO while delivering those historic judgements. However, in the present situation all the courts, starting from District Court to the Court of Appeals for the Federal Circuit to the Supreme Court have said the same thing and each higher level went on affirming/reaffirming the decisions of the earlier levels.* Many practitioners of patents may not have paid any attention to the fact that the USPTO had been awarding such patents in the normal course. Therefore this case would be a great revelation to them.

This decision will be debated by legal experts as well as by scientists, NGOs, opinion makers, economists, politicians and other for many years. But this decision is going to stay. Some questions would be asked. "Is it necessary to continue with PPA and PVPA any longer ? Who would now like to go for protection provided through UPOV? When would other countries start falling in line with this type of decision? Would this decision open doors for international negotiations? Lets wait and see.

Case Study of a Patent Granted to a Nobel Laureate

Three Scientists, Eric A Cornell, Wolfgang Ketterle and Carl E. Wieman shared the nobal prize in physics for the year 2001 for the achievement of Bose Einstein Condensate (BEC) in dilute gases of alkali atoms and for early fundamental studies of the properties of the condensate. Cornell and Wieman have got the prize for their contributions in laser research. Many people raise a question, whether a patent can be obtained around basic research or not. The answer would be yes if it is remembered that an inventive work qualifies for a patent if it is novel, non obvious and has an industrial application. The answer would be no if one of the above features is missing. The question related to basic research and applied research in this context is not relevant at all. Cornell obtained a US patent is 1997 on optical cooling of solids to extremely low temperatures by using lasers.

The patent deals with a device and method for laser cooling which includes an active cooling structure having a high purity surface passivated direct band gap semiconductor crystal of less than 3 microns thick and a transparent hemispherical body in optical contact with the crystal. The crystal is itself cooled when

illuminated with a laser beam tuned to a frequency no greater than the band gap edge frequency of the crystal. Cooling is caused by emission of photons of higher energy than photons entering the crystal, the additional energy being accounted for by process of absorption of thermal photons from the crystal lattice. Such low temperature cooling could be effectively used for infra red viewers which need cooled sensors in order to be able to image ambient thermal radiation having temperatures close to absolute zero. Another application could be in cooling superconductor integrated circuits. Optical refrigeration of diodes by flowing a current into a light emitting diode and generating photons with greater than eV worth of energy is also not effective.

Prior Art

There have been many method to cool solids to very low temperature (-200° C or lower). Cryogenic fluids are messy, expensive and bulky as well. Close cycle refrigerators have also been used for cooling solids. Use of an intense beam of monochromatic laser has been made in cooling of atomic gases by directing it into the vapour to take advantage of a mechanism internal to the atom to cause it to absorb a photon from the laser beam and then remit a photon of slightly higher

Contd on...4

Do not publish your invention before filing a patent application

Contd from...3
Case Study...

frequency. However, this technique has not been used directly in respect of solids where the laser beam enters a solid and causes a higher frequency photon to emerge.

Description of the invention

The invention provides a device and method for cooling solids utilizing laser optics. The device includes a high purity semiconductor crystal and means associated with it for reducing nonradiative recombination of photons entering the crystal.

Non radiative recombination of photons is avoided by reducing the total internal reflection of light scattered in the crystal by promoting passage of the scattered light from the semiconductor. This passage is provided by a transparent body having an index of refraction matched within selected parameters to the semiconductor crystal and a band gap larger than the band gap of the semiconductor crystal. The transparent body is held in optical contact relative to the semiconductor crystal and is to be preferably a hemisphere made of either GaP or AlGaAs. Nonradiative recombination tends to increase the temperature of the body which is contrary to the basic objective. Hence non nonradiative recombination has to be reduced. The crystal is very thin, less than 3 microns and characterized by minimal band tails such as GaAs. A passivating layer or layers of lattice matched material at the crystal, having a larger band gap than the crystal are provided to inhibit nonradiative recombination, the passivate layers preferably formed by GaInP and AlGaAs. A laser tuned to a frequency not greater than the band gap edge frequency is used for illuminating the crystal.

Figure 1 indicates the quantum mechanism allowing optical cooling by ensuring that the incoming layer is tuned such that the photons in the laser beam have just enough energy to promote an electron out of the valence band and

into the conduction band.

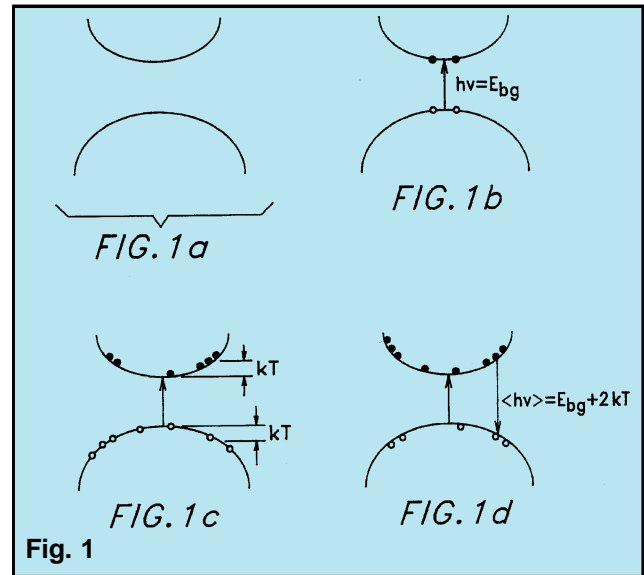
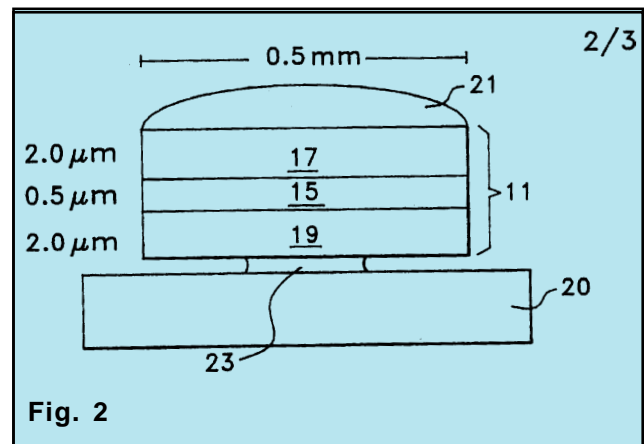

Fig 2 describes semiconductor material requirements, device geometry and pump laser requirements of the best mode for implementation of the said invention. Active cooling structure 11 may be cooled to 70 K or lower. Active cooling structure 11, including semitransparent semiconductor crystal layer 15 and passivating layers 17 and 19, is a thin film wafer grown using standard MBE or MOCVD techniques. Wafer is attached to substrate 20. Black wax 21 is used to protect and support the wafer during epitaxial liftoff. Layers 17, 15 and 19 are made of GaInP, GaAs and GaInP. Fourth layer 23 is made of AlGaAs.



Contd on...5

Contd from...4
Case Study...

Fig 3 shows the complete system or device for optical cooling of solids. It includes active cooling structure 11 sandwiched between two index matching hemispheres 25 and 27. Hemispheres 25 and 27 and structure 11 are held together by means of two gold wire harnesses 29 and 31. Each harness wraps around a hemisphere and the harnesses are fastened together by twisting together the loose ends. Gold wires provide excellent thermal conductivity allowing heat to flow from device to active cooling structure 11.

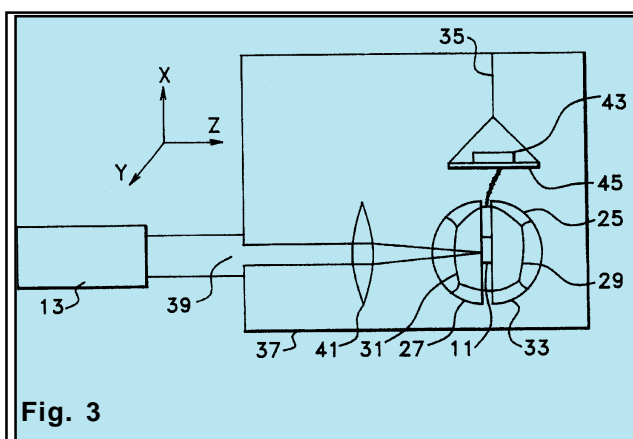

Fig. 3

Claims

The patent has 34 claims, the first claim is being reproduced.

1. A device which is cooled by illumination with a laser beam of selected frequency, said device comprising :

a high purity semitransparent crystal; and means associated with said crystal for reducing nonradiative recombination of photons entering said crystal.

Readers will note that the inventor may have to have many sub inventions to achieve the final goal like preparing the thin crystal, depositing passivating layers, evolving methods for reducing nonradiative recombination, mechanism to transfer heat, method for reducing the total internal reflection of the laser inside the crystal and so on.

States Suggest Items for Geographical Indications (GI)

PFC along with Patent Information Centres (PICs) in states of Uttar Pradesh, Madhya Pradesh, Himachal Pradesh, West Bengal, Rajasthan and Punjab had taken up an exercise of listing of some items which may qualify as candidates of GI in future. The list obtained from each of the states is given below:

Uttar Pradesh

	Items	Associated Geographical Location
1.	Glass products / Leather products Petha (Sweet)	Agra
2.	Locks in brass and iron / scissors	Aligarh
3.	Guava	Allahabad
4.	Banarasi Sarees	Azamgarh Amil
5.	Carpets, Woolen Carpets	Bhadohi Suriyawan
6.	Homeopathic Medicine	Buland Shahr, Anupshahr
7.	Melons	Etah- Soron
8.	Glass bangles / Glass wares Scientific equipment's Glass bangles / Glass tube, Glass jar Firozabad	Jasrana Shikohabad
9.	Handloom cloth/ Bed sheets Tyre Tube	Ghaziabad Pilkhua Loni
10.	Handloom cloth	Gorakhpur
11.	Bricks	Hamirpur Gohand
12.	Handloom Cloth Handloom Cloth Ranipur	Jhansi Hamirpur
13.	Leather work	Kanpur Dehat Sikandra
14.	Leather goods, cotton cloth, woolen Garment.	Kanpur Nagar Kanpur
15.	Bone Ash Brass wares	Kheri Ole Dhakwa
16.	Chicken work Crockery, Pottery Chickan work Mango	Lucknow Chinhat Kakori Malihabad and Mahona
17.	Khadi Cloth Silken Sarees Handloom Colth	Mau Amila Ghosi Maunath Bhanjan
18.	Brassware Brassware	Moradabad Chandausi Hasanpur

Contd on...6

Do not publish your invention before filing a patent application

Contd from...5

Geographical Indications...

19.	Handloom fabrics Charthawal	Muzafarnagar
20.	Catechu Bhinga	Pratapgarh
21.	Knives	Rampur
22.	Khadi Cloth Nakur	Saharanpur
23.	Electrical Goods Pipri	Sonbhadra
24.	Silken Sarees Silken Sarees	Varanasi Kotwa Lohta
25.	Marble Goods Carpets	Mirzapur Chunar

Himachal Pradesh

	Items	Associated Geographical Location
1.	Shawls	Kulu
2.	Caps	Kulu
3.	Shawls	Kinnaur
4.	Caps	Kinnaur
5.	Chappals	Chamba
6.	Tea	Kangra

Rajasthan

	Items	Associated Geographical Location
1.	Bikaneri Bhujia	Bikaner
2.	Kota Stone	Kota
3.	Bhandhej	
4.	Green Pickle and Onion and Marwadimathaniya	
5.	Chhitar Stone of Jodhpur	Jodhpur
6.	Yellow Stone of Jodhpur	Jodhpur
7.	Mats of Salawas (Jodhpur)	Jodhpur
8.	Granite of Jalore	Jalore
10.	Heena (Mehndi) of Sojat	Sojat
11.	Jink Badala	
11.	Paohpadra/ Meekalsar Ki Matkiya	
12.	Sevan Grass of Jaisalmer	Jaisalmer
13.	Bantonite	
14.	Ker, Kumti, Sangri (Khejedi Vatpad)	

Punjab

	Items	Associated Geographical Location
1.	Phulkari – A handicraft	
2.	Kotkpura Dhoda– A sweet	Kotakpur
3.	Amritsari Papad & Warian	Amritsar
4.	Patialvi uti	Patiala
5.	Muktsari Juti Punjabi Juti	Muktsar
6.	Fazilka Juti	Fazilka
7.	Patiala Nallah	Patiala
8.	Sarson Da Sag	

West Bengal

Dress Material		
	Items	Associated Geographical Location
1.	Murshidabad Silk	Murshidabad
2.	Bishnupur Baluchuri	Bishnupur
3.	Dhanekhali Saree	Dhanekhal
4.	Santipur Tant	Santipur
5.	Phuliar Tant	Phuliar
Handicrafts:		
1.	Dokra	
2.	Bankura & Bisnupur Terakota	
Food :		
1.	Bardhamaner Mihidana	Bardhaman
2.	Bardhamaner Sitabhog	Bardhaman
3.	Kolkatar Rosogolla	Kolkata
4.	Shaktigarh Lancha	Shaktigarh
5.	Krishnanagarer Sarvaja	Krishnanagar
6.	Darjeeling Tea	Darjeeling

Madhya Pradesh

	Items	Associated Geographical Location
1.	Chanderi saree	Chanderi

Visit us at www.indianpatents.org.in

Assessment of Damages in Copyright

The present copyright case decided in United Kingdom in July 2001 was between a jeweller and a gold mine owner. The claimant, Nigel Blayney was a jeweller specialising in hand made jewellery. The defendants were owners of a gold mine in Wales and supplied Welsh gold to claimant for making gold rings of a celtic design known as 'Lovers Twist', which the defendants later sold to the customers. This went on for almost two years between 1991 and 1992. However, after sometime the business relations between the two parties ended and the defendants employed another craftsmen for making and selling the gold rings of the same design as that of the claimant. Here, the copyright of the designs of the ring and the ring itself as a work of artistic craftsmanship was with the claimant and this was admitted by the defendant that making and selling of that ring by them led to copyright infringement of the claimant. The claimant did not opt for account of profits but sought damages instead. The issues before the Chancery Division of the High Court were:

- 1) How to assess such damages?
- 2) What would have happened if defendants had not sold those gold rings?
- 3) Burden of proof lay with the

claimant or the defendant.

- 4) Could copyright owner recover both damages for copyright infringement and damages for conversion?

Regarding the burden of proof, the claimant argued that it should be presumed that all sales would have been made by them in the absence of the defendants selling those rings. While the defendants said that it was for the claimant to prove the loss in their sales due to the defendant's selling the rings. The judge was also of the opinion that the burden of proof was with the claimant. As for the damages, the defendants argued that the value of copyright was £ 250 and therefore the claimant could not claim more than that as the value of the copyright would take account of its capacity to produce profits for its owner and, therefore, the value of the copyright on an outright assignment equalled the maximum loss which the copyright owner could suffer. The claimant argued that had the infringement not taken place, he would have continued to supply the same number of items to the defendants. But the defendants argued that they were fed up with the claimant and so had stopped getting work from them. Also they didn't try to contact them later. The claimant further said that he would have sold the same number of rings as the defendants although it would have taken a little longer time. However, the judge held

that there were other factors in favour of defendants like they had a strong brand name, connection with Royal family and presence of Welsh gold. The claimant didn't have all these resources at hand so it would not have made the same number of sales as the defendants. The claimant answered that he had the design, which the defendants didn't have and that was also an important factor. In absence of evidence this argument did not help in determining damages. The Court did not allow additional damages by way of royalty as the claimant failed to discharge the burden of proof by not providing convincing evidence.

It was accepted by the Court that the defendants were unaware of the copyright infringement. The Court took into account the fact that as soon as the defendants realised the seriousness of the claimant's claim, the defendants stopped infringing. Interest on the damages awarded was granted at a rate of 8% based on the assumption that the sales for each period accrued at a constant rate and interest on half the amount for the whole of the relevant period was taken. However, the judge directed that interest should cease to run nine months before the date of the judgement due to Mr. Blayney's delay between discovering the infringement in 1995 and the sending of the letter before action in May 1997.

(Source : Copyright World, November 2001, Issue 115)

Do not publish your invention before filing a patent application

Some Commonly Asked Questions Regarding Copyright

- 1. If a literary work does not carry a copyright notice, will it not be treated a copyrighted work?**

A copyright notice is not necessary to indicate or establish that the concerned work is copyrighted.

- 2. Will it be a violation of copyright if I copy the work and distribute without changing?**

Yes, it will be a violation of copyright. The only possible consolation could be that the court may not award damages. However, if your action damages the commercial interests of the copyright holder, the court can award suitable damages against you.

- 3. Is it essential to defend your copyright through practice or renewal?**

No, copyright is never lost unless an explicit licensing of the copyright has been done or the copyright has been given away. It is unlike trademarks which need to be defended for their presentation. For example, trademark has to be renewed from time to time whereas there is no need to renew copyright. Similarly if a trade mark is not used for a considerable length of time it may be put to use by some other person.

- 4. Can you copyright a name?**

You cannot copyright a name or any word. However, you can trademark them, generally by using them to refer to your brand of a generic type of product or service. For example an "Apple" computer. Apple Computer owns that word when applied to computers, even though it is an ordinary work. Apple Records owns this word when applied to music.

Something About Software Patents

A software related patent claims some feature, function or process embodied in a computer program that is executed on a computer. Most types of software that have been patented in the USA include system software, expert system software, application software, business software and user interactive software. In general, the functional aspects of software are patented, such as editing and control functions, compiling and operating system techniques. Icons and electronic font types have also been patented in the USA.

The criteria for assessing a software patent application are the same as used for assessing other applications. The invention has to be novel, non obvious and useful. Determination of novelty in the use of software patents is little difficult through the patent documents alone. Software developers traditionally ignored patenting of software. Trade secrets and later, copyright protection were generally recognized as suitable forms of protection by many, even after the historic decision of the US Supreme Court in 1981 allowing patenting of software. As a result there is a large amount of non patented software which would have to be scanned and analysed for determining novelty of a software related invention. Of course, software protected through trade secret cannot be accessed. While one needs to look at the non patent literature, one should look at classes 364 and 395 under the USPTO classification system for classifying inventions. The title of class 364 is "Electrical / Computers and Data Processing Systems" and that of 395 is "Information Processing System Organisation". These two classes should be extensively used for ascertaining the prior art.

Patent Litigation Watch

Hollywood stars Brad Pitt and Jennifer Aniston had got their wedding rings made from an Italian design Damiani International in July 2000. The rings were engraved with words 'Brad 2000' and 'Jenn 2000'. At that time an agreement had been signed between the couple and the designer that he would never reproduce rings of that design in future. But later the designer replicated the rings and sold them online. The complainants are seeking an injunction to stop the designer from selling the rings with their names and have claimed damages worth \$ 50 million.

The European Patent Office opposition division dealing with the famous Harvard University's "Oncomouse" patent has limited the patent to only transgenic rodents containing additional cancer gene. The patentee is, however, free to protect against the decision.

SmithKline Beecham has sued Endo Pharmaceuticals Holdings Inc for violating five of SmithKline's patents on the anti-depressant drug Paxil. The case has been filed in the United States Federal Court in Pennsylvania. Endo has taken a stand that it is only the generic version of the drug.

A suit has been filed by Takata Corp in the USA against General Motors (GM) and Delphi Automotive Systems for infringement of a 1992 Takata

patent for a vehicle airbag. Takata, a Japanese manufacturer of auto airbag covers seeks a court order blocking further infringement and an award of damages and claims that it had informed GM about the infringement in 1996.

State Post Bureau issued a post card in the year 2000 which covered photograph of an individual Ding Changlu without his authorisation. The court in Beijing has ordered the Bureau and its co-defendant to pay £ 135 to Ding Changlu.

An online recruitment company, Monster.com and its parent TMP Worldwide have dropped a series of lawsuits against its former employees. TMP Worldwide paid a fee to the former employees in return for a promise not to solicit Monster.com's clients or employees.

A trademark dispute between Godrej Soaps and Peshawar Soaps & Chemicals Ltd (PESCO) over the trademark 'Nikhar' has been won by Godrej Soaps. The court observed that PESCO had not used the trademark Kesh 'Nikhar' anytime before Godrej entered the market.

Silva Drugs India Ltd was manufacturing pharmaceutical preparations under the trademark Crosinal which is very similar to SmithKline Beecham's (SB) Crocin. SB moved to the court alleging that Silva Drugs was infringing their trademark and also attempting to pass off their product as that of SB's, thus creating confusion among

Contd on...10

International News

Corporation Services (Liberia) Inc is one of the IP firms in Liberia whose main goal is to allow the aspiring patent applicants to file patent, trademark, service mark and copyright applications immediately by electronic means. The firm has a team of legal specialists to provide expert advice in Liberian intellectual property law. Up-to-minute legal services are provided by the firm. The firm is equipped with hi-speed communications network to respond to inquiries immediately. Trademark search at the Registry is conducted and delivered by e-mail or fax within 24 hours time. For more details go to the website alfredtubmon@hotmail.com or send a fax to + 15308695881.

A proposed patent by agrogiant Monsanto on genetic blue prints of high-yield soybeans has caused alarms in China, where the crop has been grown for thousands of years. If this patent is granted, Monsanto's grip on the market could improve. Monsanto already receives royalties on about 60 per cent of the US soy market with its patents on genetically engineered plants resistant to herbicide.

(Economic Times, 19 Dec 2001)

For the first time, China has documented regulations on the

Contd on...10

Do not publish your invention before filing a patent application

Contd from...9

Patent Litigation Watch

consumers and chemists. The Delhi High Court granted an ex parte injunction refraining Silva Drugs to use the trademark Crosinal.

A US court has awarded \$ 182 million penalty in a lawsuit for stealing of trade secrets. Cadence Design Systems had brought a lawsuit against Avant! for stealing its software code.

Bausch & Lomb Inc has filed suit against Ciba Vision Corporation for infringing Bausch's patent on extended-wear soft contact lenser. Bausch has asked the court to block Ciba Vision from selling Focus Night & Day contact lenses in the United States.

A Chinese company, Shanghai Xiaomianyang Bedroom Appliance Co has agreed to pay the US based Dupont Co US \$ 6, 024 as compensation for making a quilt cover identical to the design Dupont had registered.

Copyright in the works of James Joyce are owned by the Estate of James Joyce which recently won an infringement case against Macmillan Publisher. The copyright on the famous book "Ulysses" written by Joyce ended in 1991 under the normal UK laws. Macmillan brought out a work "Ulysses – A Reader's Edition (edited by Danis Rose) in 1997 by utilizing some of the unpublished documents and manuscripts of James Joyce until 1977. Obviously, the Estate of James Joyce had the

copyright on these unpublished works as well. Another development took place in 1996 when a new European Legislation was introduced harmonizing the term of copyright protection for literary works. The judge ruled in October 2001 that Macmillan and Danis Rose infringed the Estate copyright on two accounts, (1) the copyright on unpublished works was held by the Estate and (ii) the copyright on the original Ulysses was revived in 1996 due to the new European Legislation. An injunction prohibiting further copies of the book was granted and Macmillan and Rose were ordered to pay compensation to the Estate.

Budejovicky Budvar, a Czech brewery has been selling Budweiser beer in Europe since 1895. Interestingly, there are two US trademarks for 'Budweiser' and 'Bud' held by Anheuser Busch, the world's largest beer producers. The Czech brewery had no choice but to market it in the USA under a different name 'Czechvar' as it could not possibly market it under the name Budweiser. More than 40 trademark suits are pending worldwide with each brewery claiming to be the owner of 'Budweiser'. Anheuser Busch claims that it has been using the name 'Budweiser' since 1876 although the Czech town once known as Budweis, where the Czech brewery is based, is known for its beer tradition since the 13th century.

Contd from...9

International News

judgement of patent infringements. A committee of the Beijing Court had invited suggestions on the judgement of patent infringements and would implement them soon. Statistics also show that Beijing Court had received 773 cases on patent matters running from 1985 to 2000.

Tunisia has become the 115th contracting state of the Patent Cooperation Treaty (PCT) after depositing its instrument of accession on December 10, 2001.

Australia's new Gene Technology Act 2000 came into force in June 2001. Under the new Act, certain dealings with genetically modified organisms (GMOs) will require a license. The Act prohibits dealings with GMOs unless :

- a) the person undertaking the dealing is authorised to do so by a GMO licence; or
- b) the dealing is a notifiable low risk dealing; or
- c) the dealing is an exempt dealing; or
- d) the dealing is included in the GMO register.

According to the Act, to "deal with", in relation to a GMO means to conduct experiments with the GMO; make, develop, produce or manufacture the

Contd on... 11

Visit us at www.indianpatents.org.in

A Domain Name Case Law

Eli Lily and Company v David Clayton

Eli Lily and Company (hereafter referred to as complainant) had obtained registration of XIGRIS as a Community Trade Mark in respect of pharmaceutical preparations. Mr David Clayton, (hereafter referred to as respondent) once an employee of the complainant, registered XIGRIS as the domain name. The complainant was setting up a website to promote the XIGRIS brand but the respondent's domain xigris.co.uk was blocking the complainant from doing it. The complainant opined that its Community Trade Mark Registration was prior to the domain name registration by the respondent. Also, the respondent was very well aware of the brand name XIGRIS when he was an employee there, so his registering the domain name xigris.co.uk was totally in bad faith. The complainant sent the notification to the respondent but he didn't respond, so mediation was not possible.

The complainant referred the case to the Nominet UK Dispute Resolution Service Policy. Under this Policy, required fee is paid for the Nominet to instruct an expert to resolve the dispute under the norms of the policy. If within a stipulated time period the respondent does not reply, the expert makes the decision. The expert in that case is entitled to draw conclusions or inferences he may find correct based on the relevant facts

available. However, this does not mean that everything submitted by the complainant shall be believed upon by the expert to be true in every sense. Actually this was the first case to be decided under the new Dispute Resolution Service.

The complainant had to prove to the expert that it had right to stop the respondent from using his brand name in respect of the similarity of the domain name to the brand. Except .co.uk the domain name of the respondent was exactly similar to that of the complainant's brand. Secondly, the complainant had to prove that the act of the respondent was equivalent to an Abusive Registration.

In this case, Abusive Registration could not be proved as such. The complainant further submitted that the respondent's registration was detrimental to trade mark rights of the complainant but could not substantiate this point. The complainant also added that registration of the respondent was in bad faith as he had done this already knowing of trademark's existence when he was an employee at that place. Thirdly, since pharmaceutical preparations were involved, public health and public safety issues also arose from possible unauthorized use.

The respondent here had a chance to prove that his registering the domain name was not an Abusive Registration but he made no submission whatsoever. The expert finally ordered the domain name xigris.co.uk to be transferred to the complainant.

(Source : *Intellectual Property Devisions, Dec 2001*)

Contd from...10

International News

GMO; breed, propagate, grow, raise or culture the GMO; use the GMO in the course of manufacture of a thing that is not the GMO; or to import the GMO. In addition, it also includes the possession, supply, use, transport or disposal of the GMO for the purposes of any of the foregoing.

The penalties prescribed for offences under the Act include substantial financial penalties as well as jail sentences. An "aggravated offence", for example, is punishable by imprisonment for up to five years.

New Zealand has a new Trade Marks Bill to replace the existing Trade Marks Act 1953. It aims to ensure that New Zealand trade mark law better meets the needs of the business community; and addresses Maori concerns regarding the registration of Maori works and symbols as trade marks. The major changes are as follows:

- Multiclass applications will be registrable,
- Part A and part B will be replaced by a single register,
- Threshold for registrability will be 'capable of distinguishing'.
- There will be a 10 year term, renewable every 10-years thereafter,
- There will be a three year non-use period, *Contd on...12*

Do not publish your invention before filing a patent application

Patents for Opposition

The following patent applications have been accepted by the Patent office and published in the Gazette of India. These can now be opposed by filing opposition applications within a period of four months from the dates given. Six digit numbers allotted after acceptance by the Patent office are given before the applicant names and patent application numbers given in brackets. Names of the branches of the Patent office are denoted in the application number, e.g. 'Bom' for Bombay branch. An opposition application should be submitted at the appropriate office where the concerned application was originally filed.

PATENT APPLICANTS

INVENTION

A. 6 October 2001

186561. Allegheny Ludlum Corp, USA (344/Del/93)	A method and apparatus for continuously producing crystalline metal strip
186562. Mohammad Shakir Qidwai, UP (382/Del/93)	A papad making machine
186563. Krupp Polysius Ag, A Germany (0391/Del/93)	Rotary drum
186564. Brentwood Industries Inc A Corp, USA (402/Del/93)	Corrugated sheet article
186565. The Gillette Comp., USA (414/Del/93)	An improved method of manufacturing a polyfluorocarbon coated razor blade
186566. Novapharm Research Australia Pty Ltd, Australia (418/Del/93)	Pressure dispensing pump
186567. Dr Omvir Singh Chaudhary, Indian (430/Del/93)	A device to control the oscillatory angle of a table fan
186568. Gillette Canada Inc, Canada (489/Del/93)	Dental floss brush and method for manufacturing same
186569. Orbital Engine Co., Australia Pty Ltd, Australia (492/Del/93)	Apparatus for delivering fuel and a combustion control substance to internal combustion engines
186570. Harjinder Singh Cheema, India (573/Del/93)	A device for moulding bricks and tiles
186571. Godrej And Boyce Mfg Co Ltd, India (127/Bom/96)	An improved aldrep
186572. Rajesh Om Prakash Mehta India (52/Bom/96)	An attachment for mixer grinder
186573. Indian Institute Of Technology Bombay, Mumbai (370/Bom/97)	A process for preparation of granulated non living biomass of the fungus rhaopus species for sorption of toxic trace and heavy metals and organic chemicals from effluents
186574. Department Of Atomic Energy, India (439/Bom/97)	An optical probe for quantitative evaluation/ measurement of defects in a ferromagnetic material component
186575. Andrew Corp, USA (443/Bom/97)	Method of producing a cable assembly and the resulting assembly
186576. Hindustan Lever Ltd, India (670/Bom/97)	A method of producing a food product compressing antifreeze polypeptides
186577. Hindustan Lever Ltd, India (240/Bom/99)	An improved process for producing tea concentrate

Contd from...11

International News

- Comparative advertising will not constitute infringement.

Innovative 'Wearable Computing Company' Orang-Otang Computers, Inc. has been granted patent protection for its line of wearable technology. The patented innovations include wearable computers, PDAs, pagers, telephones and keyboards.

(World Patent Information, December 2001)

A Computer Software Authors Act has been introduced in Iran. As per the new law the authors of computer software own rights of reproduction, presentation, enforcement and economic and moral exploitation or utilization over the software. The Act provides protection only if the subject was first produced and distributed in Iran. The duration of economic rights is 30 years from the date of creation while the duration of moral rights is unlimited.

In Colombia, photographs must have an artistic value to be protected by copyright, in contrast with literary, musical or artistic works. This provision seeks to prevent the protection of mechanical phototgraphs with copyright. As with other authors, photographers have economic and moral rights. According to their

Contd on...13

Visit us at www.indianpatents.org.in

186578. J B Chemicals And Pharmaceuticals Ltd, Mumbai (35/Mum/00)
 186579. Rallis India Ltd, India (736/Mum/00)

186580. Sulphur Mills Ltd, Mumbai (778/Mum/00)
 186581. Hindustan Antibiotic Ltd, India (568/Bom/97)
 186582. Hindustan Antibiotic Ltd, India (567/Bom/97)
 186583. The Indian Card Clothing Co Ltd, (195/Bom/97)
 186584. Koproan Ltd, Mumbai (227/Bom/99)

186585. Gharda Chemicals Ltd, Maharashtra (332/Bom/99)
 186586. Mitsu Industries Ltd, India (521/Bom/99)

186587. Cipla Ltd, Mumbai (583/Bom/99)
 186588. Dr Daftary Gautam Vinod Siro Research Foundation, Maharashtra I (535/Bom/99)
 186589. Sun Pharmaceuticals Industries Ltd, Maharashtra (654/Bom/99)
 186590. Bayer Corp, USA (840/Bom/99)
 186591. Nova Mont Spa, Italy (1309/Cal/95)

186592. Nur Advanced Technologies Ltd, Israel (1339/Cal/95)
 186593. The Dubois Plc, London (1385/Cal/95)
 186594. Merck Patent Gesellschaft Mit Bescharankter, Germany (1683/Cal/95)
 186595. I M A Industria Macchine Automatiche, Italy (31/Cal/96)
 186596. Laboratorios Del Dr Esteve, Spain (104/Cal/96)

186597. Hindustan Development Corp Ltd, Kolkata (218/Cal/96)
 186598. Asta Medica Ag, Germany (317/Cal/99)
 186599. Dr Subhash Chandra Mondal etc India (609/Cal/99)
 186600. Liu Jian, Canada (7/Cal/00)

A process for the preparation of pharmaceutical dental formulation

A process for the preparation of an insecticidal composition of pyrethroid fenvalerate and organophosphorous acephate

An improved process of manufacturing/ fungicide composition in the dry flowable form

A process of preparation water soluble derivative of aureofungin

A simple method to prepare water soluble derivative of hamycin

High population tops for man made fibres in carding machine

An improved process for the synthesis of 5 2 ethoxy 5 4 methylpiperazin 1 ylsulphonyl phenyl 1 methyl 3 n propyl 1 6 dihydro 7h pyraxolo 4 3 d pyrimidin 7 one sildenafil

An improved process for the manufacture of 0 0 diethyl 0 quinoxaliny 2 thiophosphate

Process of preparation of unsubstituted or substituted aromatic alcohols from aromatic aldehydes in liquid phase

An improved process for the manufacture of carvidilol

A process for preparation of sterile cisplatin oil in water emulsion with reduced toxicity suitable for parenteral administration

A process for the preparation of iopamidol in a pharmaceutically acceptable form

A process for preparing 4 amino 1 2 4 triazoloin 5 ones

A process for preparing biodegradable and water dispersable plastic sticks with cotton buds at the ends thereof

A duplex printing apparatus and method of manufacturing a printed substrate

Apparatus for holding a compact disc

Pigment composition

Apparatus for withdrawing and opening flat folded blanks from a magazine and for feeding them to a packaging line

A process for the preparation of a stable oral pharmaceutical preparation of an acid labile benzimidazole compound

A method of making wear resistant long life rails

Process for the preparation of crystalline thioctic acid

A method for the extraction of lupeol acetate from the leaves of ficus recemosa

Isolation and purification of paclitaxel and other related taxanes by industrial preparative low pressure chromatography on a polymeric resin column

Contd on Supplement

Contd from...12
International News

economic rights, they may reproduce, distribute, exhibit and sell their work. Their moral rights entitle them to have their name and the year of production of the work printed visibly on any reproduction of the same. The law does not make exceptions as to the means through which the photograph is reproduced, so even the owners of web sites that would want to include a photo on line must respect the economic and moral rights of the author.

With effect from July 2001 the access to digital copying for private use has been liberalised in Denmark. The new rules imply that one is only allowed to copy text, music, and images, etc. in digital form for private use, e.g. with a view to recording of radio and television programmes for viewing at a later time, copying of a music CD for the car, the summer cottage or for a walkman, copying for a compilation CD and copying for a PC with a view to electronic execution within the household. Copying of computer software in digitalised form is still banned. One is still not allowed to copy computer software as e.g. operating systems for computers, executive and retrieval programs in databases and multimedia works, word processing programs

Contd on...14

Do not publish your invention before filing a patent application

Contd from...13

International News

and computer and console games. Digital copying in connection with work or for internal use in any business or enterprise, etc. is not subject to this new act and is therefore still banned.

(Copyright World, Nov 2001)

A new Registered Designs Act has come into force in Denmark with effect from 1 October 2001. Under the new Act, the initial term is 5 years, which may be renewed for 5-year periods. What is new is that through such 5-year periods the protection may be extended for up to 25 years. A shorter maximum protection period of 15 years applies to design for a component used in the repair of a composite in order that the product returns to its original appearance. This rule is especially significant with regard to spare parts for cars.

(Copyright World, Dec 2001)

The US Copyright Office has launched copyright search which is internet based. One could access more than 13 million records of copyright ownership. The database covers books, films, music, software, periodicals etc. registered since 1978.

(http://www.ipr-helpdesk.org/t_en/n_003_f_en.asp?urlid=957)

(World Patent Information, Dec 2001)

Domestic News

The much awaited Plant Varieties and Farmers Right Bill, 2001 has received President's consent. It was been notified in the Gazette of India as Act No 53 of 2001. The Act in compliance with the TRIPS seeks to stimulate investment for R&D and facilitate growth of the seed industry in the country through domestic and foreign investments.

(The Hindu, 6 Nov 2001)

Wockhardt has recently filed seven patents in the areas of new chemical entities and novel drug delivery systems (NDDS). This brings the total patents filed during 2001 to 20 patents and a total tally of 50 patents filed so far by Wockhardt.

(Financial Express, 31 Oct 2001)

According to World Intellectual Property Organisation (WIPO), India has ranked fourth among the developing countries in terms of number of patent applications filed under the Patent Cooperation Treaty (PCT) during the first nine months of the current fiscal. India has filed around 248 PCT applications upto September 2001. Republic of Korea was at the top with 1,714 PCT applications, followed by China (1085) and South Africa (945).

A US patent has been

granted for a herbal drug invented by scientists of the Allahabad University. The drug is active against dermatophytosis or ringworm or tinea infection and is free from side-effects having a broad anti-fungal spectrum.

(The Hindu, 29 Nov 2001)

Boss Profiles Ltd has applied for patents in many countries for three- dimensional ceramic products, as versatile as marble. Unlike conventional tiles, 3D architectural ceramics have a wide variety of applications as they can be used for curved and flat surfaces.

(Financial Express, 18 Dec 2001)

National Research Development Corporation (NRDC) has developed an Interactive Multimedia Training Package on intellectual property rights titled, 'Key to New Wealth' on a CD-ROM. The package provides information about different types of IPRs in detail. Information about law books, case studies related to IPRs, seminars and training programs is given in a very lucid and user friendly manner. The package is of use to scientists, research institutions, lawyers and even IPR experts. The package, available for Rs 20,000/- offers more than 10,000 pages of information related to IPR. For further information on

Contd on...15

Visit us at www.indianpatents.org.in

Contd from...14
Domestic News

this package visit the website
www.nrdcindia.com

Bharat Biotech has filed a patent for the manufacturing process for recombinant hepatitis B vaccine. The process called Himax Technology eliminates the side-effects and increases the recovery of the hepatitis B surface antigen upto 85% . It has also obtained a patent for Lysostaphin used for curing post-operational infection.

The Patent Office Technical Society, Kolkata has brought out a reference book on Registration of Designs. The book contains frequently asked questions about design registration in India, the Designs Act 2000 and Design Rules, 2001. The document also contains the fee schedule, the various forms and list of classifications of goods under different classes. The book priced at Rs. 50/- can be obtained from : The Patent Office Technical Society, Nizam Palace, 234/4, Acharya Jagadish Chandra Bose Road, Kolkata – 700020

The World Bank report released recently has recommended a phased implementation of TRIPS Agreement to ensure health for all by 2015. It also says that if developing countries were to fully

implement TRIPS, they would have to pay abroad over \$ 20 billion in technology –related payments and foot the expenses for local enforcement. According to the report, a rebalancing of the Uruguay Round Agreement on TRIPS should take place and it should be implemented in a phased manner with donor-funded technical assistance. A more liberal use of compulsory licenses should also be followed to encourage competition, as per the report.

(Hindustan Times, 1 Nov 2001)

A major victory has been achieved by an Indian drug company, Ranbaxy Pharmaceuticals Inc. along with others in a US Court against GlaxoSmithKline. The Geneva-Teva–Ranbaxy consortium has been able to get a revision in the expiry period of a GlaxoSmithKline patent of the \$ 1.3 billion antibiotic Amoxyclav to December 2002 from 2018. As a result of this ruling Ranbaxy Pharmaceuticals Inc. (a subsidiary of Ranbaxy Laboratories), Geneva of US and Teva of Israel will be able to launch the generic version of the drug.

(Financial Express, 19 Dec 2001)

Indian Courts have been handling many cases of trademark infringement and

passing off and many judgments have been given in the recent past. Some of the important ones are:

1. Gillette Company vs Sanghvi Writing Industry: Delhi High Court vacated injunction in favour of Gillette and allowed Sanghvi Industries to use trademark Flexgrip.
2. Himalaya Drug Company vs Strassenburg Pharma: the former restrained from marketing its product under the mark EFCID-CA.
3. Shayoka Fashions vs AB Volvo: the former restrained from using the trademark VOLVO.
4. Orchid Chemicals and Pharmaceuticals vs F. Hoffman-Roche: the former restrained from using the trademark Caltrol for its product which was found similar to the trademark ROCARTROL used by the latter.
5. Hindustan Grease vs. Castrol Ltd: the former restrained from selling brake fluid in a maroon plastic container similar to one used by the latter.

Do not publish your invention before filing a patent application

PFC on the move...

PFC has organised eight workshops in the months of November and December 2001. PFC had envisaged organizing subject specific workshops in association with Patent Information Centres. PFC organized 3 such subject specific workshops out of which two workshops specifically focused on agriculture and one on textiles. One agriculture specific workshop was organized at Rajasthan Agricultural University, Bikaner, Rajasthan on November 21, 2001 and second at Bidhan Chandra Krishi Vishwavidyalaya, Kalyani, West Bengal on December 12, 2001. One textile specific workshop was organized at M.L.V. Textile Institute, Bhilwara, Rajasthan on November 28, 2001.



(Workshop held at Rajasthan Agricultural University)

PFC has also organized two workshops one at S.J. College, Agra on November 20, 2001 and



(Workshop at Bidhan Chandra Krishi Vishwavidyalaya)

second at Umed Hospital, Jodhpur on December 12, 2001. All these workshops were organised in association with the concerned Patent Information Centres. These five workshops were attended by about 600 scientists and technologists.

PFC continued to work with Ministry of Small Scale Industries and assisted technically and financially in organizing three IPR awareness workshops one each at Agra on November 24, 2001, Ahmedabad on November 7, 2001 and New Delhi on November 2, 2001. These were attended by a total of about 350 delegates from small scale industry units.

PFC has facilitated filing of four patent applications in the month of November and December 2001.

Please send us questions and topics you would like to see in the coming issues

NEXT ISSUE

- **Case Study**
- **Patent Litigation Watch**
- **Patents for Opposition**

Published by: Patent Facilitating Centre (PFC)

Technology Information, Forecasting and Assessment Council (TIFAC)
Department of Science and Technology (DST),
Technology Bhavan, New Mehrauli Road, New Delhi - 110 016
Tel.: 6859581, 6863877, 6967458, 6567373 Fax: 6863866
e-mail: tifac@nda.vsnl.net.in website: www.indianpatents.org.in and
www.tifac.org.in

Adviser: Y.S. Rajan, Executive Director, TIFAC

Editor: R. Saha, Director

Printed by Reliant Press Pvt. Ltd., New Delhi-110 020

Telefax: 692 4567, 692 9593 e-mail : reliantpress@yahoo.com

Visit us at www.indianpatents.org.in